

EMERGENCY LIGHTING INVERTER

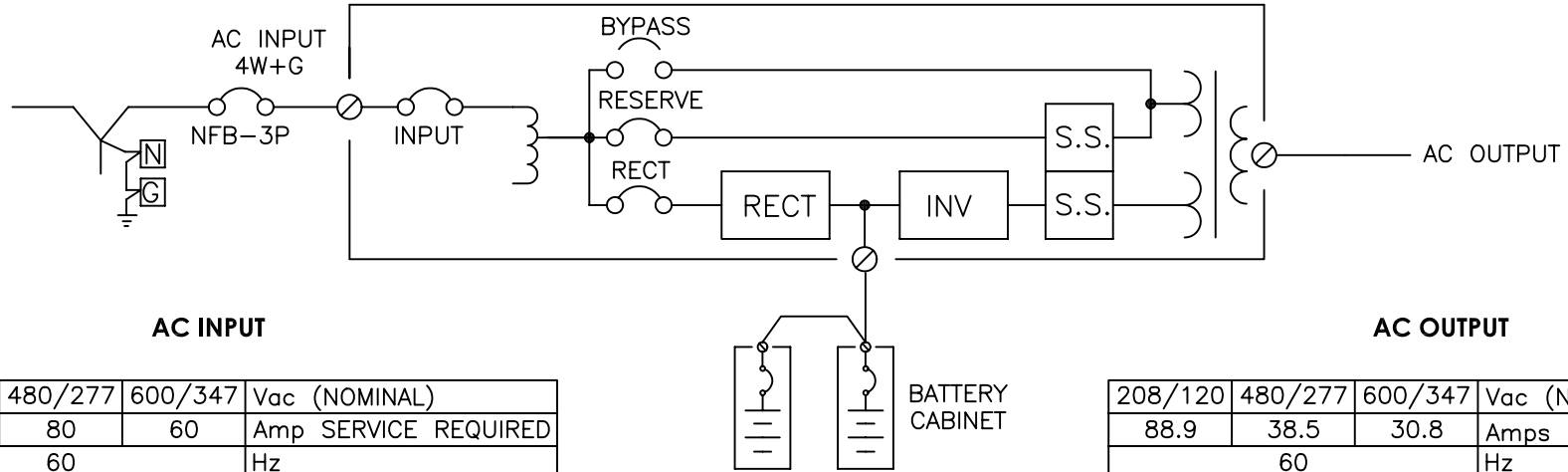

AC INPUT

208/120	480/277	600/347	Vac (NOMINAL)
175	80	60	Amp SERVICE REQUIRED
			60 Hz
			3 PHASE
			4 WIRE PLUS GROUND

AC OUTPUT

208/120	480/277	600/347	Vac (NOMINAL)
88.9	38.5	30.8	Amps (MAXIMUM)
			60 Hz
			3 PHASE
			4 WIRE PLUS GROUND

BATTERY DATA

BATTERIES: Always On

TYPE: VRLA

RUN TIME: 60, 90 MINUTES

BTU RATING

BTU 9990
KW 2.93

STANDARD

SNMP
F.A. CONTACTS
AS400 CARD

Always On UPS Systems Inc.		Kelowna B.C. alwayson.com PH:877-259-2976
BOREALIS 32KW SINGLE LINE 60/90 MINUTE BBU		Reproduction and/or use without express permission is prohibited by law.
FILE: BOREALIS 32KW 60_90MIN	VERSION: 1.0	DRAWN BY: HL
PAGE: 1/2	DATE: 080724	PROJECT: BOREALIS DESIGNED BY: AA

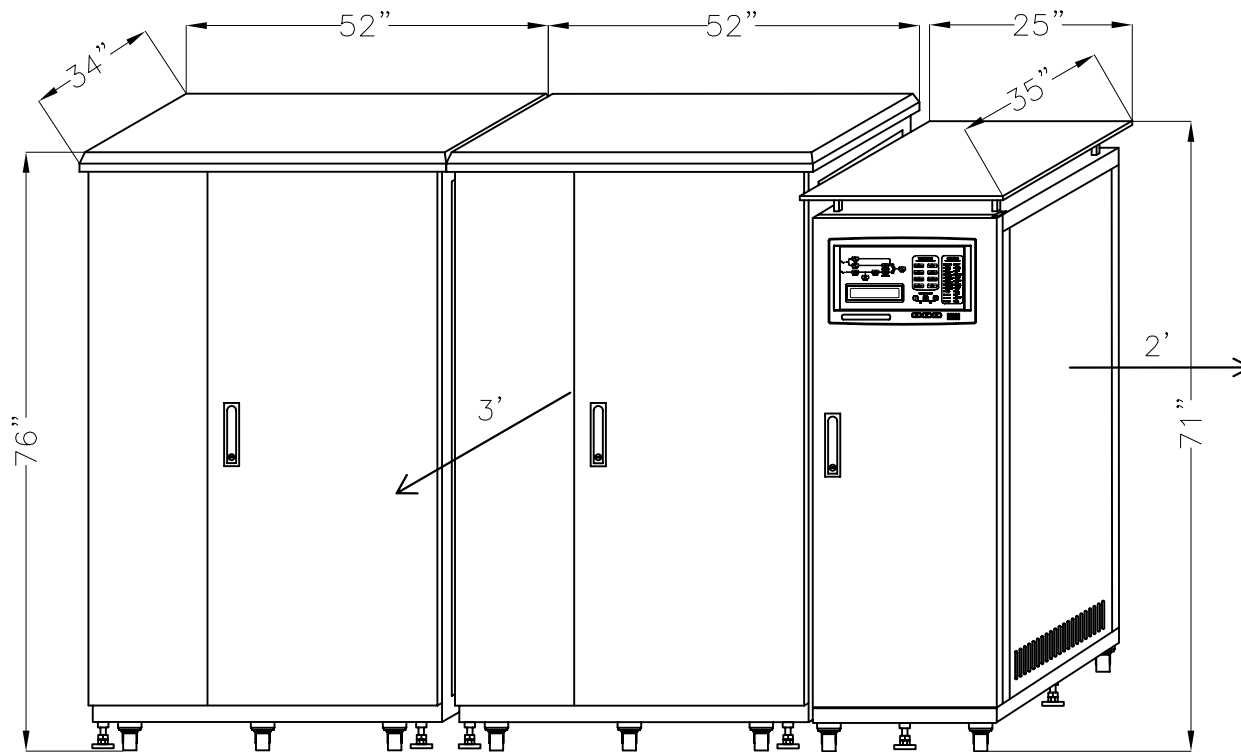

BATTERY CABINET
52"X34"X76"

BATTERY CABINET
52"X34"X76"

ELI CABINET WITH DRIP SHIELD
25"X35"X71"

WEIGHT

ELI CABINET 1433LBS / 650KG

BATTERY CABINET 2X (LBS/KG)

60MIN	90MIN
3083/1398	3890/1764

STANDARD

DRIP SHIELD

Always On UPS Systems Inc.

Kelowna B.C.
alwayson.com
PH:877-259-2976

BOREALIS 32KW DIMENSION
60/90 MINUTE BBU

Reproduction and/or
use without express
permission is
prohibited by law.

FILE: BOREALIS 32KW 60_90MIN

VERSION: 1.0

DRAWN BY: HL

PAGE: 2/2

DATE: 080724

PROJECT: BOREALIS

DESIGNED BY: AA